

NNP11X2 - Low Temperature Ultra Miniature Horizontal Piezo NanoPositioner

Specifications

- Small Size 11x11x9.33mm
- Stroke: 3 mm, 20-1,100 nm step size
- Fine scanning range: 5 μ m @300K / 0.7 μ m @4.2K
- Temperature range: 10 mK-373K
- Resistive Position Sensor with 200 nm resolution
- Pressure Range: 1E3 - 1E-9 mbar
- Magnetic field range: 0-31T
- Maximum Load: 0.25 N
- Maximum Dynamic Load Along the motion axis: 1 N
- Weight: 5 gram

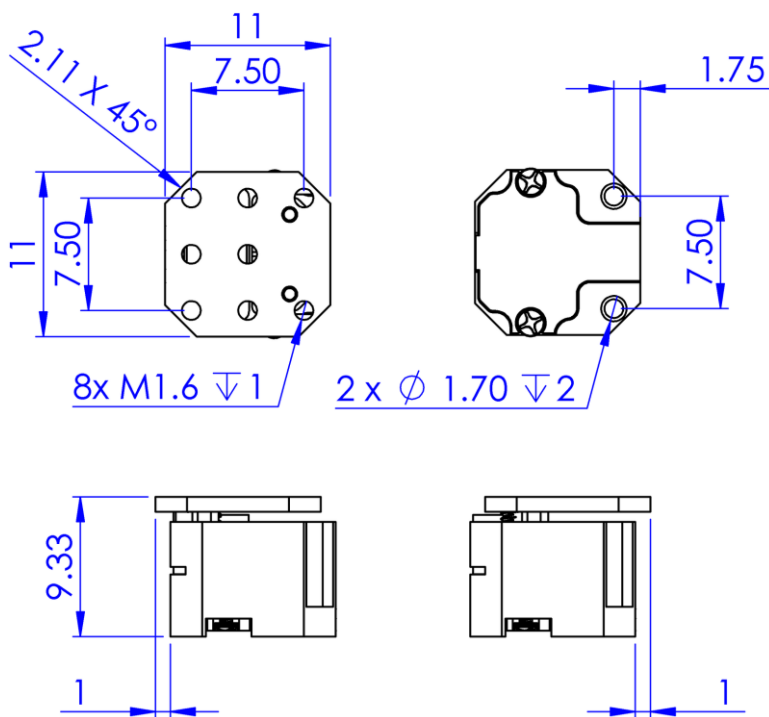
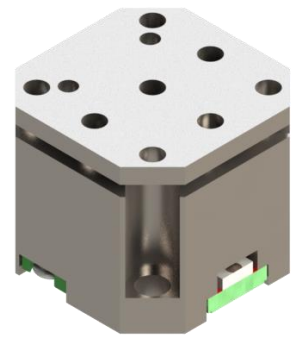

XYZ configuration



NANOMAGNETICS
INSTRUMENTS

Address : Suite 290, 266 Banbury Road, Oxford U.K.

Phone : +44 186 552 2989

Mailbox : sales@nanomagnetics-inst.com

www.nanomagnetics-inst.com

NNP11Z4 - Low Temperature Ultra Miniature Vertical Piezo NanoPositioner

Specifications

- Small Size 11x11x14.40-18.40mm
- Stroke: 3 mm, 20-1,100 nm step size
- Fine scanning range: 5 μ m @300K / 0.7 μ m @4.2K
- Temperature range: 10 mK-373K
- Resistive Position Sensor with 200 nm resolution
- Pressure Range : 1E3 - 1E-9 mbar
- Magnetic field range: 0-31T
- Maximum Load : 0.15 N
- Maximum Dynamic Load Along the motion axis : 0.5 N
- Weight: 3.5 gram

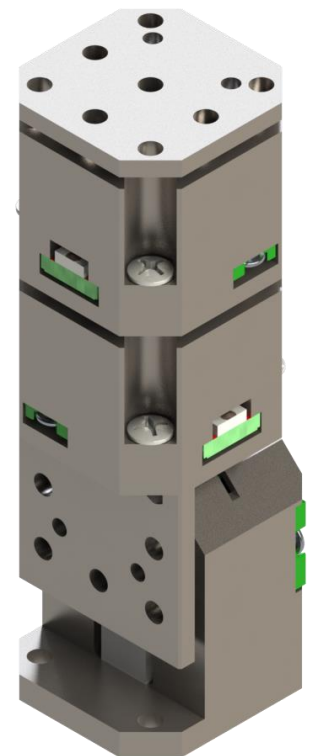
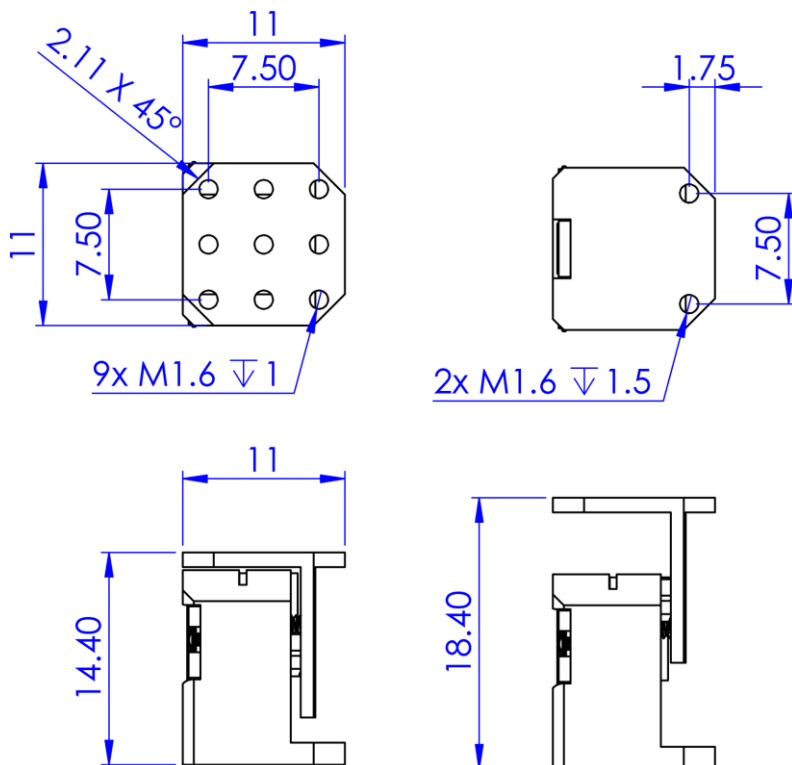
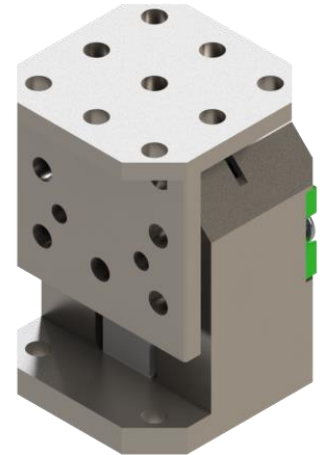

XYZ configuration



NANOMAGNETICS
INSTRUMENTS

Address : Suite 290, 266 Banbury Road, Oxford U.K.

Phone : +44 186 552 2989

Mailbox : sales@nanomagnetics-inst.com

www.nanomagnetics-inst.com

NNP14X4 - Low Temperature Horizontal Piezo NanoPositioner

Specifications

- Size: 14x14x9.20mm
- Stroke: 3 mm, 20-1,100 nm step size
- Fine scanning range: 5 μ m @300K / 0.7 μ m @4.2K
- Temperature range: 10 mK-373K
- Resistive Position Sensor with 200 nm resolution
- Pressure Range : 1E3 - 1E-9 mbar
- Magnetic field range: 0-31T
- Maximum Load: 0.25 N
- Maximum Dynamic Load Along the motion axis : 1 N
- Weight: 5 gram

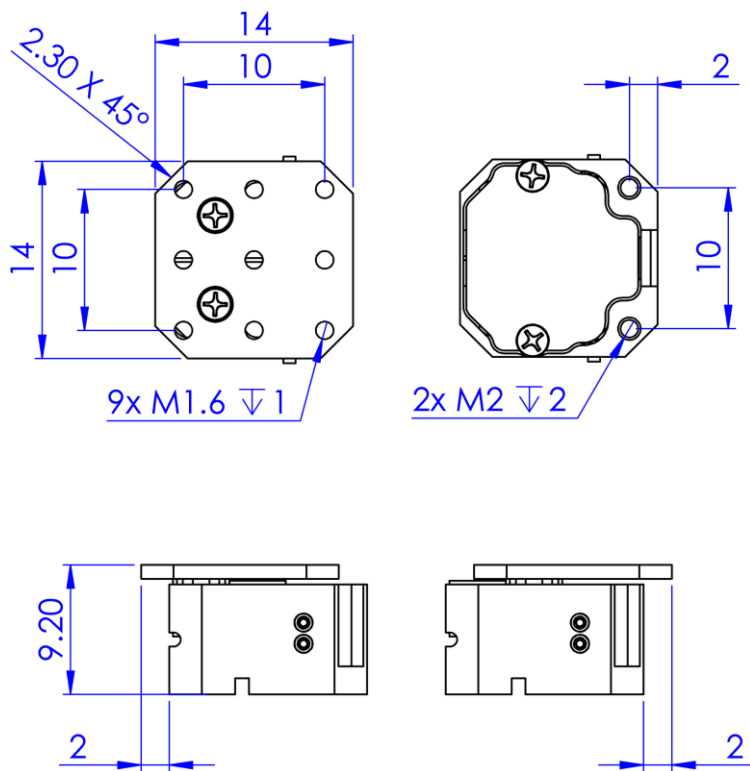
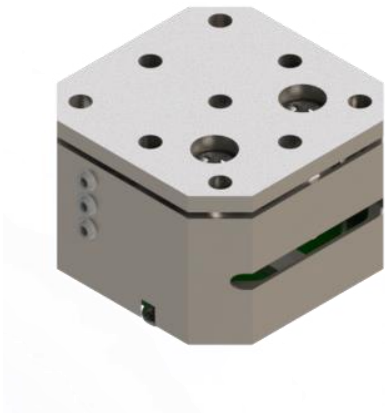

XYZ configuration



NANOMAGNETICS
INSTRUMENTS

Address : Suite 290, 266 Banbury Road, Oxford U.K.

Phone : +44 186 552 2989

Mailbox : sales@nanomagnetics-inst.com

www.nanomagnetics-inst.com

NNP14Z6 - Low Temperature Vertical Piezo NanoPositioner

Specifications

- Size: 14x14x17.50-23.50mm
- Stroke: 5 mm, 20-1,100 nm step size
- Fine scanning range: 5 μ m @300K / 0.7 μ m @4.2K
- Temperature range: 10 mK-373K
- Resistive Position Sensor with 200 nm resolution
- Pressure Range : 1E3 - 1E-9 mbar
- Magnetic field range: 0-31T
- Maximum Load : 0.5 N
- Maximum Dynamic Load Along the motion axis : 1 N
- Weight: 7 gram

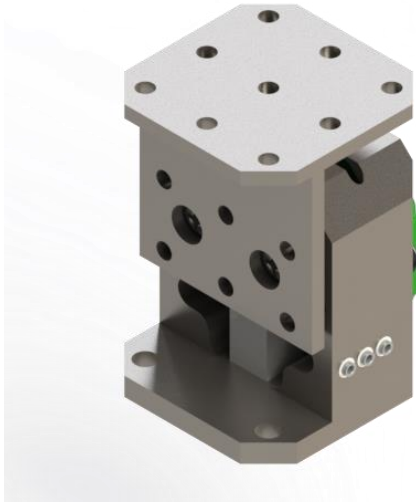

XYZ configuration

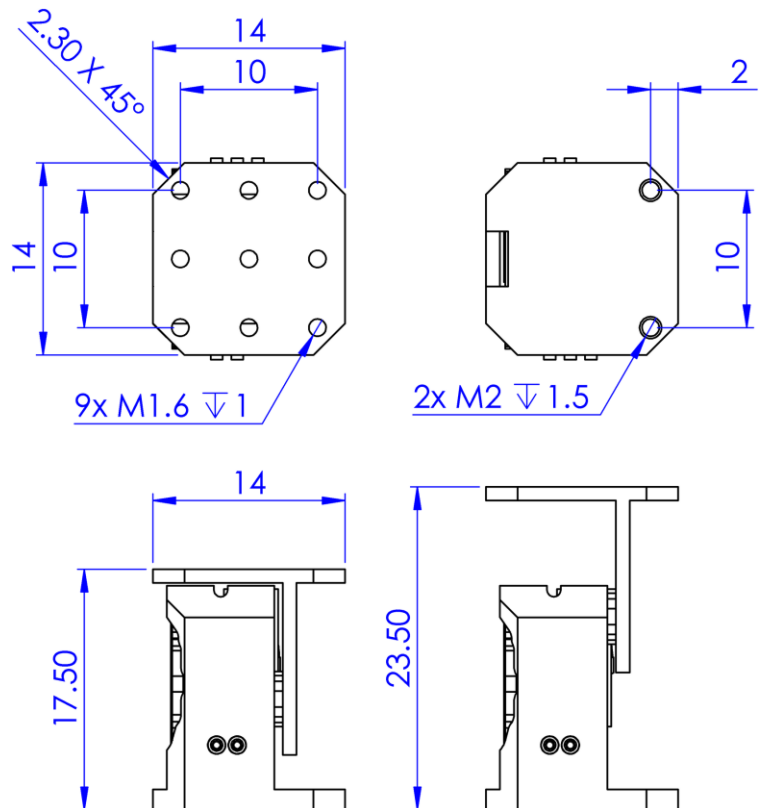

NANOMAGNETICS
INSTRUMENTS

Address : Suite 290, 266 Banbury Road, Oxford U.K.

Phone : +44 186 552 2989

Mailbox : sales@nanomagnetics-inst.com

www.nanomagnetics-inst.com

NNP24X6 - Low Temperature Horizontal Piezo NanoPositioner

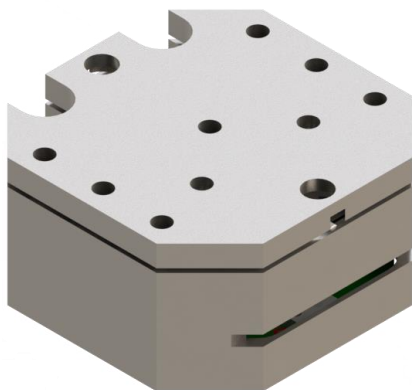

Specifications

- Size: 24x24x12mm
- Stroke: 5 mm, 20-1,100 nm step size
- Fine scanning range : 7.5 μ m @300K / 1 μ m @4.2K
- Temperature range: 10 mK-373K
- Resistive Position Sensor with 200 nm resolution
- Pressure Range : 1E3 - 1E-9 mbar
- Magnetic field range: 0-31T
- Maximum Load : 1 N
- Maximum Dynamic Load Along the motion axis : 2 N
- Weight: 18 gram

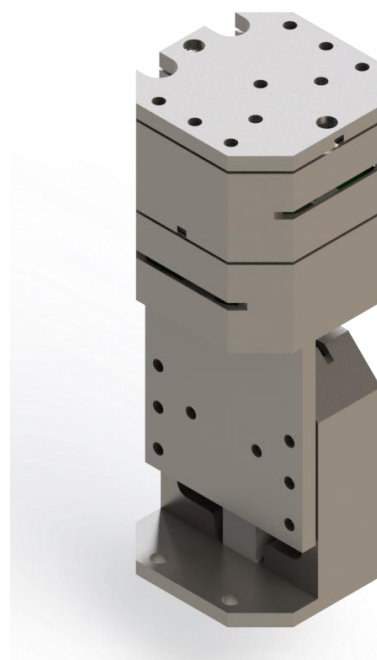
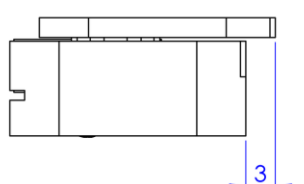
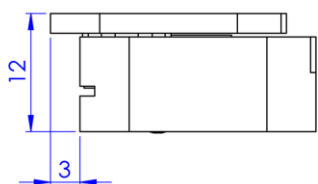
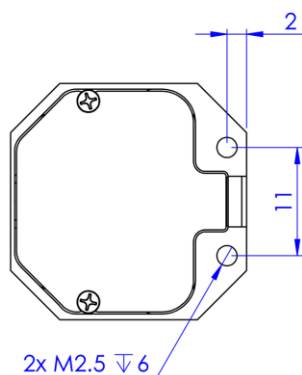
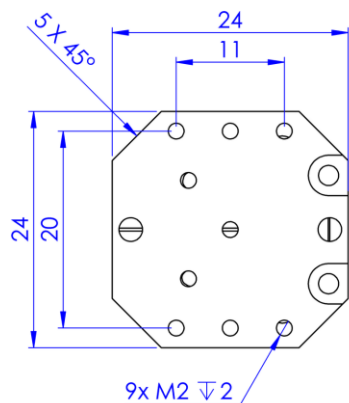

XYZ configuration



NANOMAGNETICS
INSTRUMENTS

Address : Suite 290, 266 Banbury Road, Oxford U.K.

Phone : +44 186 552 2989

Mailbox : sales@nanomagnetics-inst.com

www.nanomagnetics-inst.com

NNP24Z12 - Low Temperature Vertical Piezo NanoPositioner

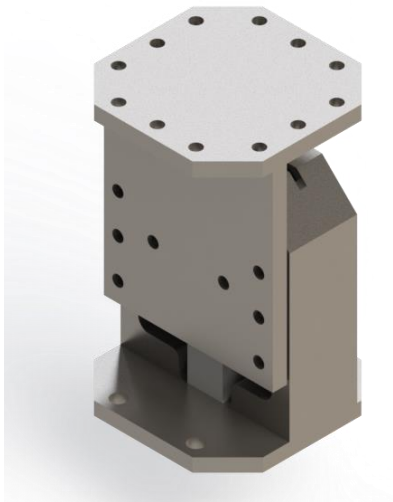

Specifications

- Size: 24x24x32.20-44.20mm
- Stroke: 11 mm, 20-1,100 nm step size
- Fine scanning range : 7.5 μ m @300K / 1 μ m @4.2K
- Temperature range: 10 mK-373K
- Resistive Position Sensor with 200 nm resolution
- Pressure Range: 1E3 - 1E-9 mbar
- Magnetic field range: 0-31T
- Maximum Load : 2 N
- Maximum Dynamic Load Along the motion axis : 5 N
- Weight: 30 gram

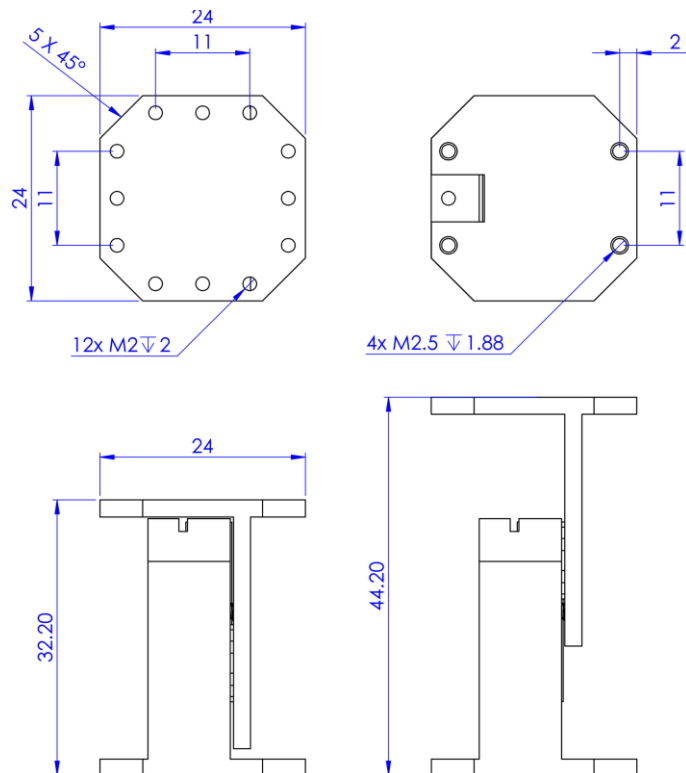
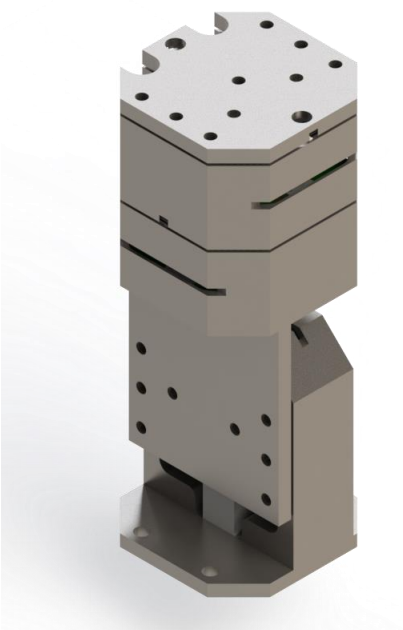

XYZ configuration



NANOMAGNETICS
INSTRUMENTS

Address : Suite 290, 266 Banbury Road, Oxford U.K.

Phone : +44 186 552 2989

Mailbox : sales@nanomagnetics-inst.com

www.nanomagnetics-inst.com